

CHAPTER 3.0 – INSTALLATION DETAILS

3.1 INSTALL REAR HINGE PINS (R-313 SYSTEM)

The Vulcan Shear Pin Load Cell was designed for dump truck and trailer applications. This shear pin replaces the 2-1/2" diameter pins in existing lift hoists and rear hinge assemblies.

3.1.1 The wheel wells or fenders may need to be removed for better access to the rear hinge assemblies.



Figure 3.1-A



Figure 3.1-B

3.1.2 Remove original hinge pins. This may take some effort as the old pins may have rust or other build up that might make it difficult to remove.



Figure 3.1-C



Figure 3.1-D

3.1.3 Insert new Vulcan Shear Pins into hinge assembly (connectors inboard).



Figure 3.1-E



Figure 3.1-F

For proper weighing, the Vulcan Shear Pin load cells must be positioned so the sensing axis is vertical (flat area around the shear pocket is vertical as shown in Figure 3.1-E). The pin also must be installed with the **serial numbers right side up** (refer to Figure 3.1-F).

3.1.4 Tack retaining collars into place.

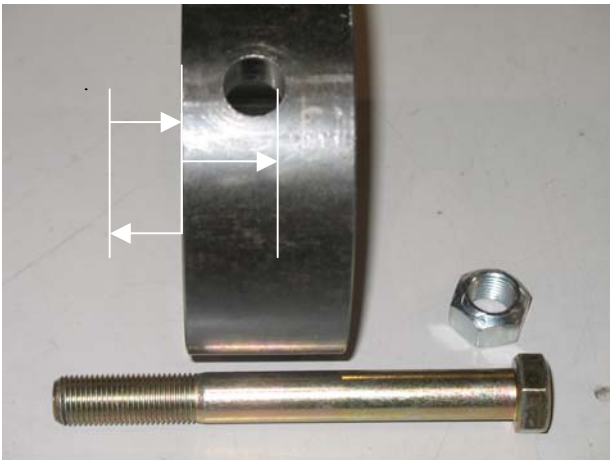

Figure 3.1-G

Notice that the bolt hole in the retaining collar is offset to one side. Be sure that when the bolt is installed through the Shear Pin load cell, the grooved shear pockets on the load cell are centered on the inside edge of the hinge assembly. The collar can be installed either way, as long as the pin is centered in the hinge.

Position the VULCAN Shear Pin Load Cell with the grooved shear pockets centered on the inside edge of the mounting brackets. Slide the shear pin retaining collar over the shear pin load cell and verify which offset, 15/16" or 1-3/16", is needed to have the retaining screw hole on the retaining collar line up with the retaining screw hole on the shear pin load cell.

Note: If the mounting brackets are not made of 3/4" or 1" material, the installer must make sure to fabricate a shear pin retaining collar with the appropriate hole location.

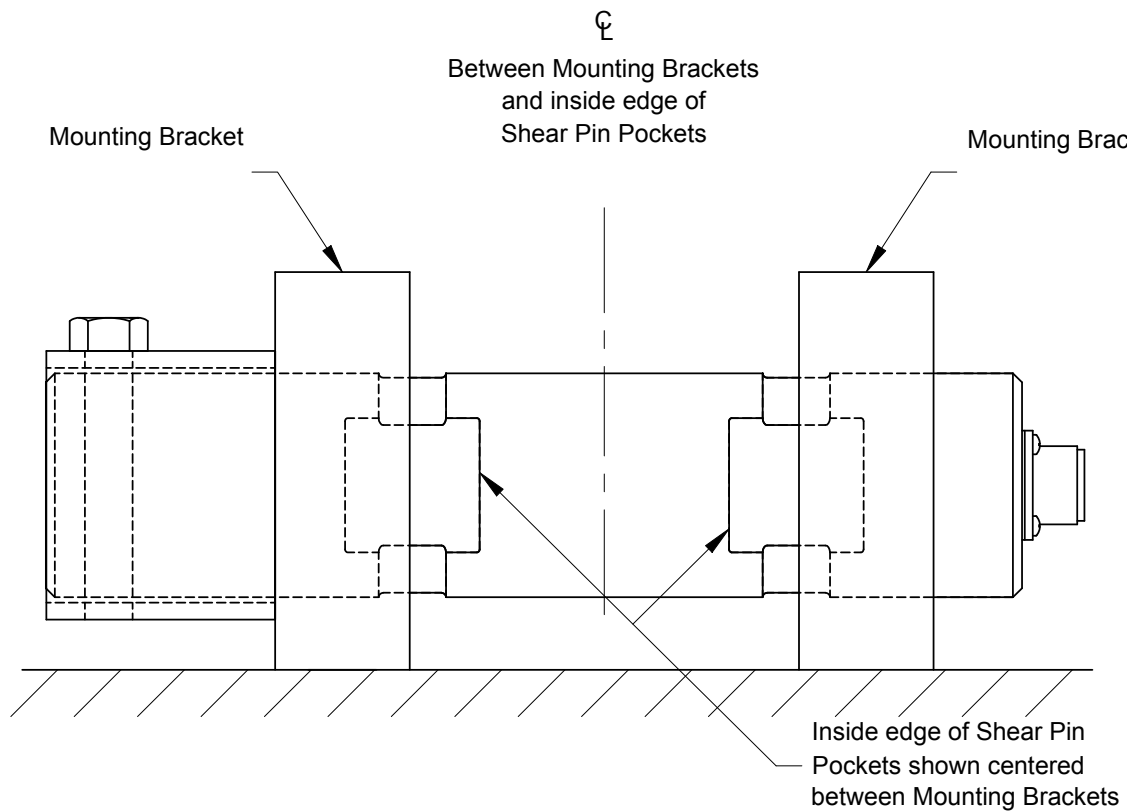

Figure 3.1-H



Figure 3.1-I

Tack the shear pin retaining collar to the hinge assembly making sure the retaining bolt will be vertical within a couple of degrees. (refer to Figure 3.1-F)

Note: Be sure to use substantial tack welds to eliminate heat distortion when welding.

Avoid excessive heat so the shear pin load cell is not damaged. After tacking the collars in place, push the Shear Pin load cells back into the hinge before welding. (refer to Figure 3.1-I)

3.1.5 Weld retaining collars into place.



Figure 3.1-J

(Caution! Do not exceed 140 degrees Fahrenheit (60 C) on the load cell. Arcing on the body of the load cell may seriously damage the load cell's structural integrity and must NOT be installed if this occurs. This also voids manufacturer's warranty.)

All welding and welding procedures *must* meet the American Welding Society Specifications. The specification of the welding electrode, as well as proper preparation of the weld area, is dependent on the composition and thickness of the frame material. If there is any doubt about which welding process to use, contact the frame manufacturer for clarification

3.2 INSTALL REAR HINGE PINS (R-323 SYSTEM)

This installation is similar to the R-313 system (see Section 3.1). The difference is that this system requires the installation of the H47 hinge kit.

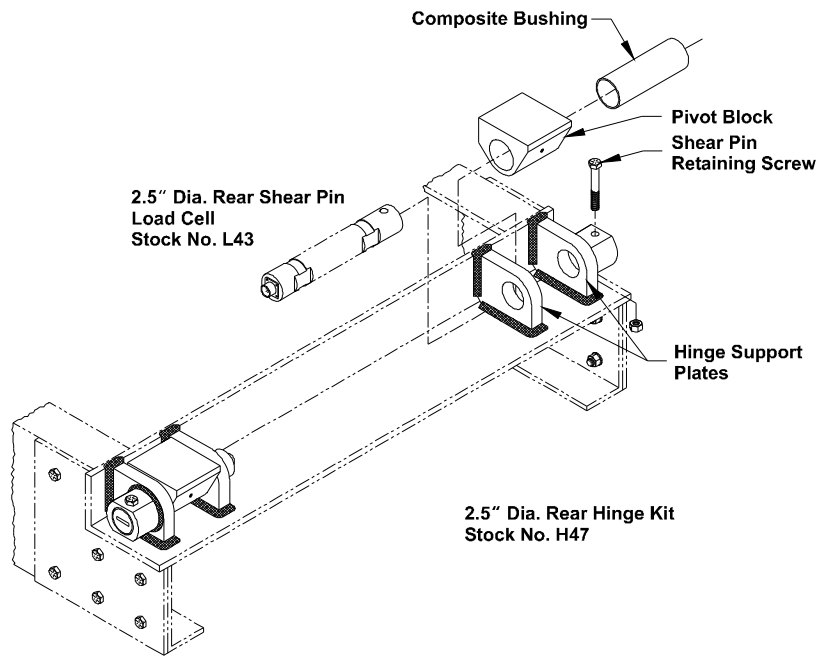

Set up Pivot Block with grease zerk fitting towards rear of truck

Weld 3, 3/8" passes on both sides of Hinge Support Plates

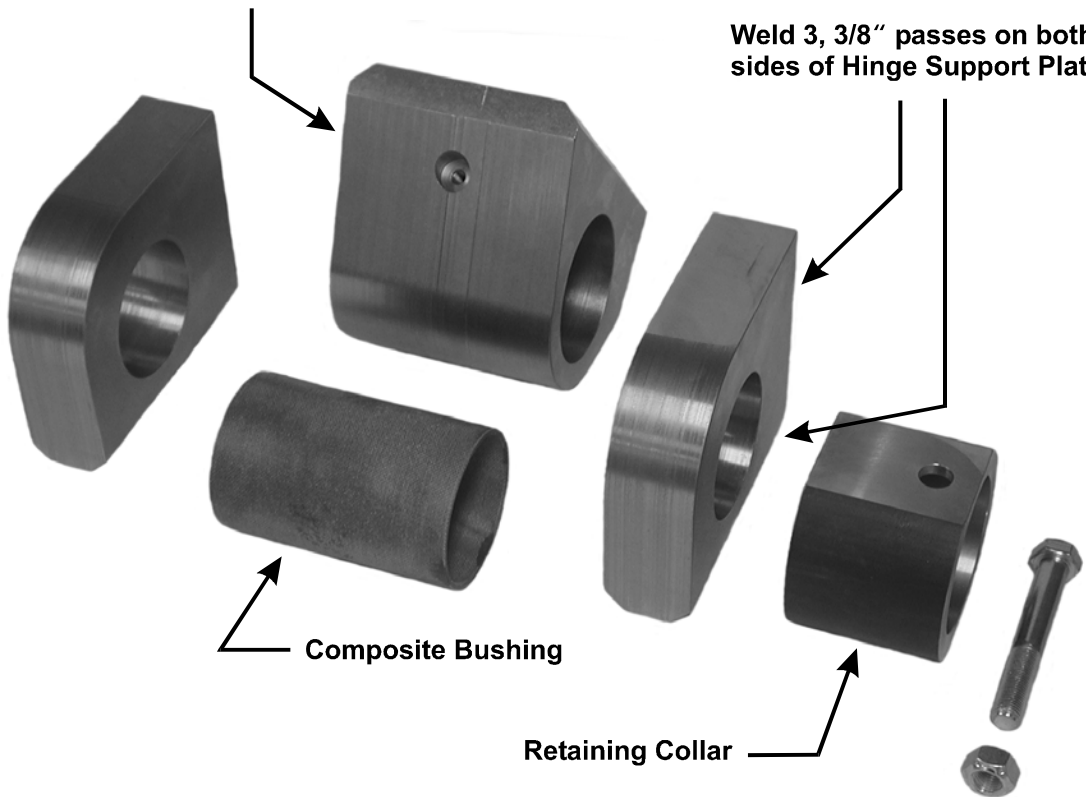

Weld 3, 3/8" passes on both sides of Hinge Support Plates

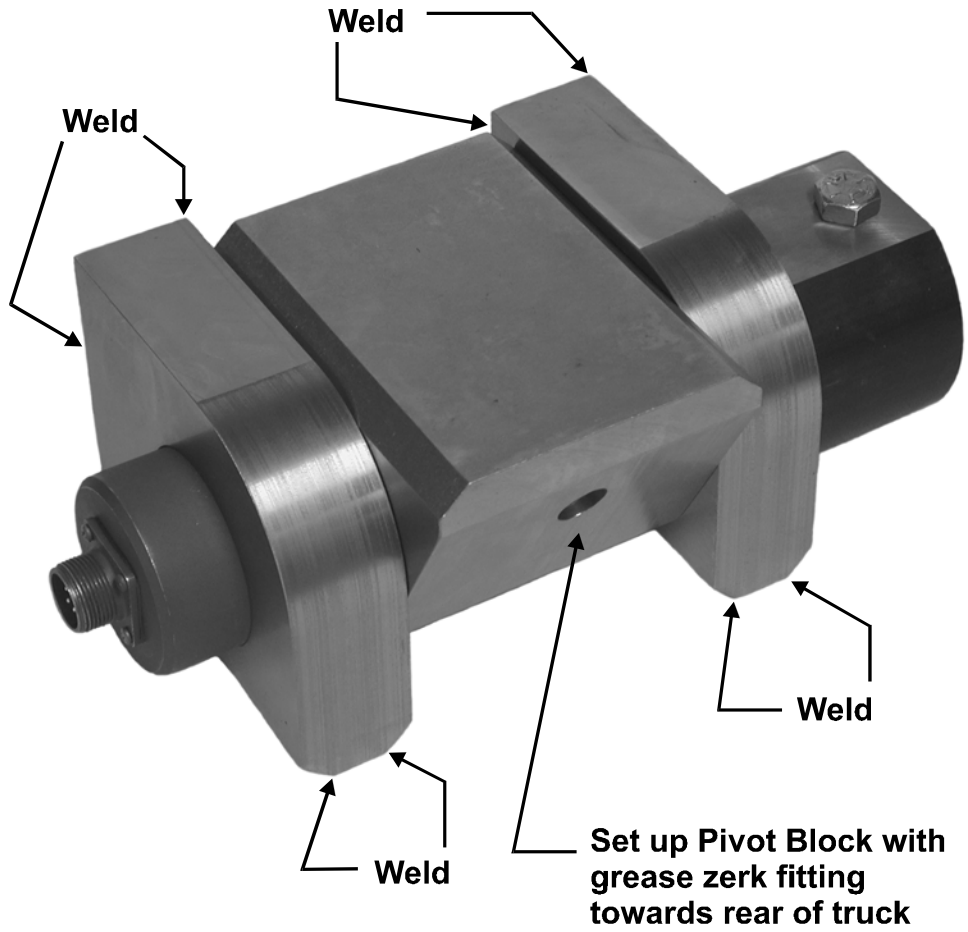

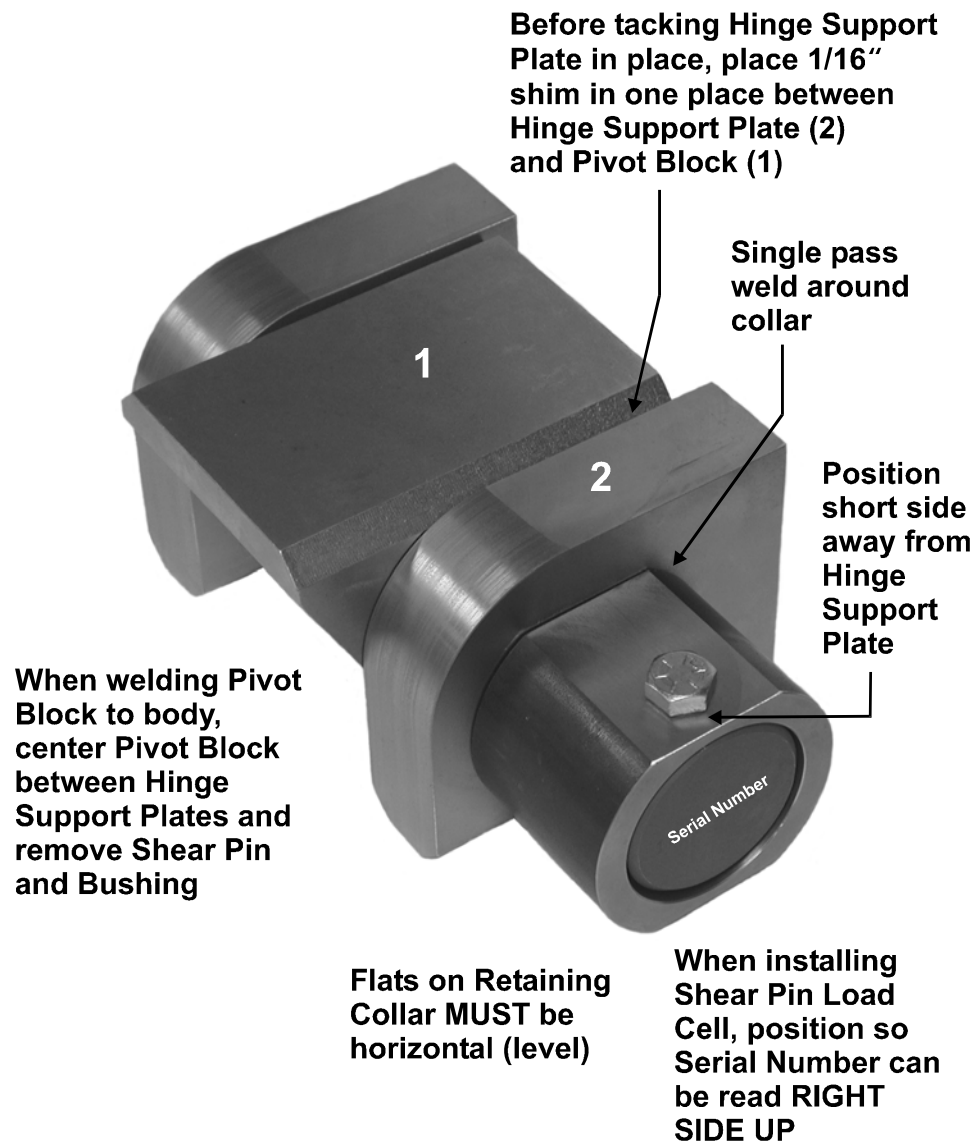

3.3 INSTALL VSL HYDRAULIC SENSOR

The Vulcan Hydraulic Pressure Sensor is designed to provide an accurate measure of payload, by measuring the hydraulic pressure in the lift cylinders. The sensor converts pressure into a corresponding weight and can be used in conjunction with Vulcan load cells to provide complete weight information where hydraulics, shear pins, or other load cells are used together.

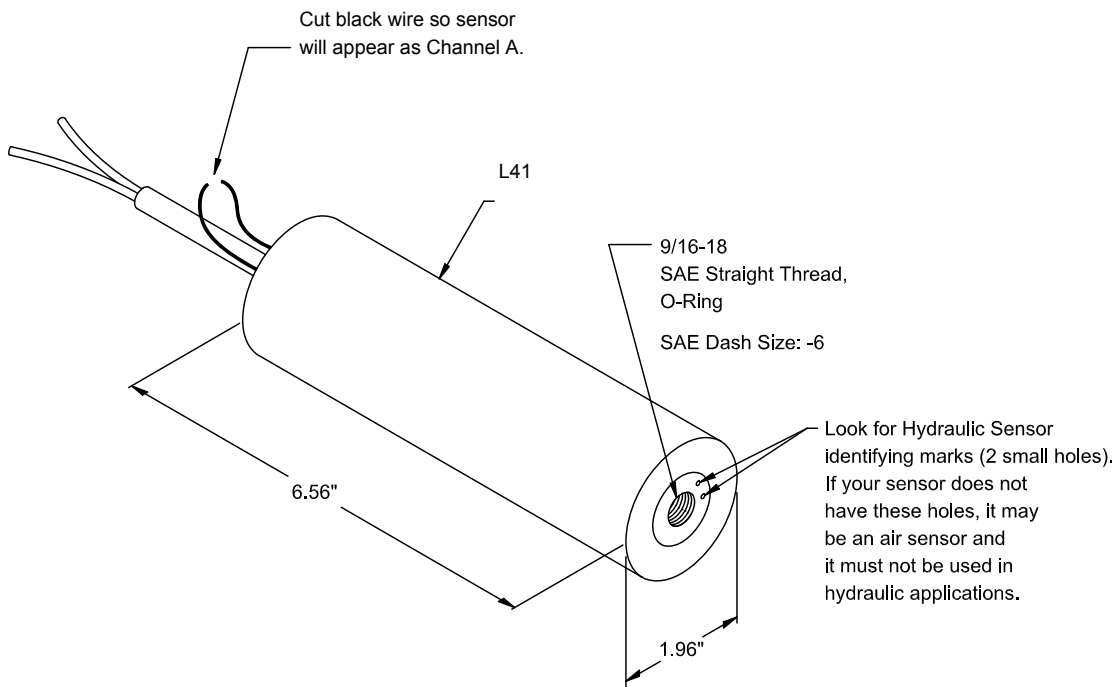

Figure 3.3-A

3.3.1 USING A FLEXIBLE HOSE CONNECTION:

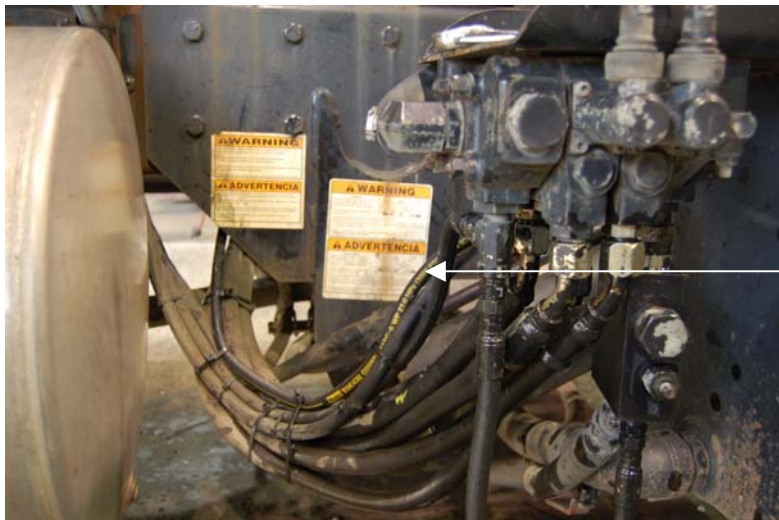

Figure 3.3-B

Figure 3.3-B shows a flexible hose connection. The hose is attached to the spool valve manifold with a T connector, and then runs to the inside of the truck chassis frame rails. This is where the hydraulic pressure sensor is installed and protected from moving parts and road hazards.

1. Find a suitable location to “T” into the hydraulic line between the hydraulic lift cylinder and the Spool Valve.

Note: The hydraulic pressure sensor must have live cylinder pressure (actual pressure inside the cylinder) at all times.